

# Miele

## Operating and installation instructions

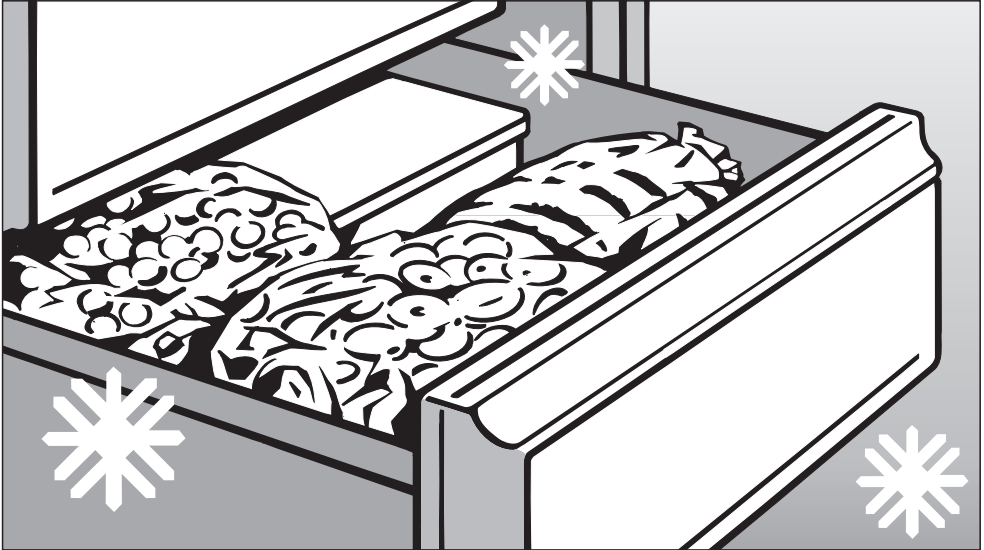

Frost-free freezer  
FN 11827 S  
FN 12827 S  
FN 12827 S edt/cs

To avoid the risk of accidents or damage to the appliance, it is **essential** to read these instructions before it is installed and used for the first time.

en - GB

M.-Nr. 09 171 780

# Contents

---

<b>Guide to the appliance</b> . . . . .	4
<b>Caring for the environment</b> . . . . .	5
<b>Warning and Safety instructions</b> . . . . .	6
<b>How to save energy</b> . . . . .	11
<b>Switching on and off</b> . . . . .	12
Switching off for longer periods of time . . . . .	13
<b>The correct temperature</b> . . . . .	14
Setting the temperature . . . . .	14
Temperature display . . . . .	15
<b>Alarm</b> . . . . .	16
Activating the alarm system. . . . .	16
Switching the alarm off early . . . . .	16
<b>Super freeze</b> . . . . .	17
<b>Freezing and storing food</b> . . . . .	18
Maximum freezing capacity. . . . .	18
Freezing fresh food . . . . .	18
Isolation plate. . . . .	18
Important. . . . .	18
Storing frozen food . . . . .	19
Home freezing . . . . .	20
Hints on home freezing. . . . .	20
Packing . . . . .	20
Before placing food in the freezer . . . . .	21
Placing food in the freezer . . . . .	21
Freezing large items . . . . .	21
Defrosting . . . . .	21
Ice cubes. . . . .	22
Cooling drinks . . . . .	22
Freezer tray . . . . .	22
Cool pack. . . . .	23
<b>Defrosting</b> . . . . .	24
<b>Cleaning and care</b> . . . . .	25
Cleaning the interior and accessories . . . . .	25
Appliance door, side panels . . . . .	26
Ventilation gaps . . . . .	26
Door seal . . . . .	26
Metal grille at the back of the appliance . . . . .	27

<b>Problem solving guide</b> .....	28
<b>Noises</b> .....	30
<b>After Sales / Guarantee</b> .....	31
<b>Electrical connection</b> .....	32
<b>Installation</b> .....	33
Location .....	33
Climate range .....	33
Ventilation .....	34
Installation .....	34
Aligning the appliance .....	34
Appliance dimensions .....	35
<b>Installing in a side-by-side combination</b> .....	36
Installation .....	36
Joining the two appliances together .....	36
<b>Changing the door hinging</b> .....	40
<b>Aligning the appliance door</b> .....	45
<b>Building in the appliance</b> .....	46

# Guide to the appliance

**Miele**

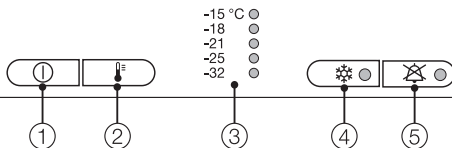

① On/Off button

② Temperature selector button

③ Temperature display

④ Super freeze button and indicator light

⑤ Alarm off button and indicator light

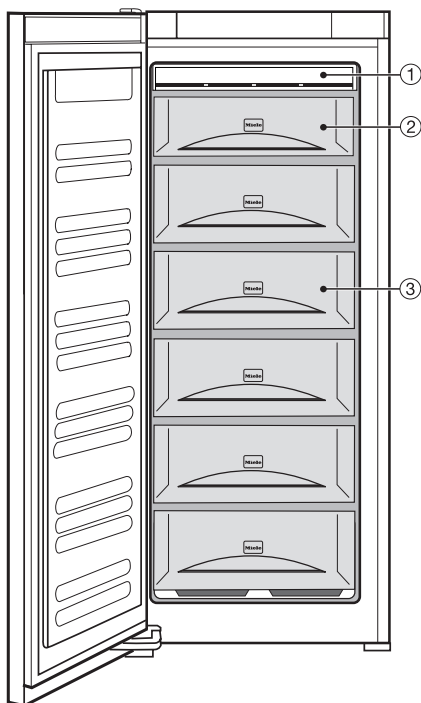

① Frost free system

② Shallow freezer drawer

③ Freezer drawers

### Disposal of the packing material

The transport and protective packing has been selected from materials which are environmentally friendly for disposal, and should be recycled.

Ensure that any plastic wrappings, bags etc. are disposed of safely and kept out of the reach of babies and young children. Danger of suffocation!

### Disposal of your old appliance

Electrical and electronic appliances often contain materials which, if handled or disposed of incorrectly, could be potentially hazardous to human health and to the environment. They are, however, essential for the correct functioning of your appliance. Please do not therefore dispose of it with your household waste.

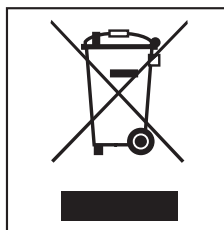

Please dispose of it at your local community waste collection / recycling centre or contact your dealer for advice. Ensure that it presents no danger to children while being stored for disposal.

Take care not to damage the pipework at the back of it before or during transportation to an authorised collection depot.

In this way, refrigerant in the pipework and oil in the compressor will be contained, and will not leak out into the environment.

# Warning and Safety instructions

---

This appliance complies with all relevant legal safety requirements. Improper use can, however, present a risk of both personal injury and material damage.

To avoid the risk of accidents and damage to the appliance, please read these instructions carefully before installation and before using it for the first time. They contain important notes on the installation, safety, operation and care of the appliance.

Keep these instructions in a safe place and pass them on to any future user.

## Correct application

► This appliance is not designed for commercial use. It is intended for use in domestic households and in similar working and residential environments such as:

- Shops
- Offices and showrooms
- Hostels and guest houses.

This appliance is not intended for outdoor use.

It must only be used as a domestic appliance to store deep frozen food, to freeze fresh food and to prepare ice.

Any other usage is not supported by the manufacturer and could be dangerous. Miele cannot be held liable for damage resulting from incorrect or improper use or operation of the appliance.

► This appliance is not intended for use by people with reduced physical, sensory or mental capabilities, or lack of experience and knowledge, unless they are supervised whilst using it, or have been shown how to use it correctly by a person responsible for their safety.

## Safety with children

► Children 8 years and older may use the appliance only if they have been shown how to use it in a safe way and understand the hazards involved.

► Children under 8 years of age must be kept away from the appliance unless they are constantly supervised.

► This appliance is not a toy! To prevent the risk of injury, do not allow children to play with it or near it or to play with the controls, or to swing on the door.

# Warning and Safety instructions

## Technical safety

► Before setting up the appliance, check it for any externally visible damage. Do not install and use a damaged appliance.

It could be dangerous.

► If the connection cable is faulty it must only be replaced by a service technician authorised by the manufacturer to protect the user from danger.



**R600a**

► This appliance contains the coolant Isobutane (R600a), a natural gas which is environmentally friendly. Although it is flammable, it does not damage the ozone layer and does not increase the greenhouse effect. The use of this coolant has, however, led to a slight increase in the noise level of the appliance. In addition to the noise of the compressor, you might be able to hear the coolant flowing around the system. This is unavoidable, but does not have any adverse effect on the performance of the appliance. Care must be taken during the transportation and installation of the appliance that no parts of the cooling system are damaged. Leaking coolant can damage the eyes.

In the event of any damage:

- avoid open flames and anything which creates a spark,

- disconnect from the mains,
- air the room in which the appliance is located for several minutes and
- contact the Service Department for advice.

► The more coolant there is in an appliance, the larger the room it should be installed in. In the event of a leakage, if the appliance is in a small room, there is the danger of combustible gases building up. For every 8 g of coolant at least 1 m<sup>3</sup> of room space is required. The amount of coolant in the appliance is stated on the data plate inside the appliance.

► Safe operation of the appliance is only assured if it has been installed and connected in accordance with these operating and installation instructions.

► Before connecting the appliance, make sure that the connection data on the data plate (voltage and connected load) match the mains electricity supply.

This data must correspond in order to avoid the risk of damage to the appliance. Consult a qualified electrician if in any doubt.

► Do not connect the appliance to the mains electricity supply by a multi-socket unit or an extension lead. These do not guarantee the required safety of the appliance (e.g. danger of overheating).

# Warning and Safety instructions

---

- ▶ The electrical safety of this appliance can only be guaranteed when continuity is complete between it and an effective earthing system which complies with current local and national safety regulations. It is most important that this basic safety requirement is present and tested regularly, and where there is any doubt, the household wiring system should be inspected by a qualified electrician. The manufacturer cannot be held liable for damage or injury caused by the lack of or inadequacy of an effective earthing system (e.g. electric shock).
- ▶ Installation, maintenance and repairs may only be carried out by a suitably qualified and competent person in strict accordance with current national and local safety regulations. Repairs and other work by unqualified persons could be dangerous. The manufacturer cannot be held liable for unauthorised work.
- ▶ While the appliance is under guarantee, repairs should only be undertaken by a service technician authorised by the manufacturer. Otherwise the guarantee will be invalidated.
- ▶ The appliance must be isolated from the electricity supply during installation, maintenance and repair work.
- ▶ Faulty components must only be replaced by genuine Miele original spare parts. The manufacturer can only guarantee the safety of the appliance when Miele replacement parts are used.
- ▶ This appliance must not be used in a non-stationary location (e.g. on a ship).
- ▶ In countries where there are areas which may be subject to infestation by cockroaches or other vermin, pay particular attention to keeping the appliance and its surroundings in a clean condition at all times. Any damage which may be caused by cockroaches or other vermin will not be covered by the guarantee.



# Warning and Safety instructions

---

## Correct use

▶ Never handle frozen food with wet hands. Your hands may freeze to the frozen food. Danger of frost burn.

▶ Do not take ice cubes out with your bare hands and never place ice cubes or ice lollies in your mouth straight from the freezer.

The very low temperature of the frozen ice or lollies can cause frost burn to the lips and tongue.

▶ Do not refreeze thawed or partially thawed food.

Defrosted food should be used up as quickly as possible, as food soon loses its nutritional value and goes off.

Defrosted food may only be re-frozen after it has been cooked.

▶ Observe the "use by" dates given on food to avoid the risk of food poisoning. Storage times will depend on several factors, including the freshness and quality of the food as well as the temperature at which it is stored. Follow the instructions given on food manufacturer's packaging on storage conditions required, as well as the "use by" date.

▶ Do not store explosive materials in the appliance or any products containing propellants (e.g. spray cans). Thermostats switching on may produce sparks which could present a fire hazard. Flammable compounds could explode.

▶ Do not operate any electrical equipment (e.g. an electric ice-cream maker) inside the appliance. Danger of sparking and explosion.

▶ Do not store cans or bottles containing carbonated drinks or liquids which could freeze in the freezer. The cans or bottles could explode.

Danger of injury and damage to the appliance.

▶ When cooling drinks quickly in the freezer, make sure bottles are not left in for more than one hour, otherwise they could burst, resulting in injury or damage.

▶ Do not use sharp edged objects to

- remove frost and ice,
- separate frozen foods or remove ice trays.

They will damage the evaporator, causing irreversible damage to the appliance.

▶ Do not use any oils or grease on the door seal, as these will cause the seal to deteriorate and become porous with time.

▶ Do not block the ventilation gaps in the appliance as this would impair the efficiency of the appliance, increase the electricity consumption and could cause damage to the appliance.

# Warning and Safety instructions

---

▶ The appliance is designed for use within certain climate ranges (ambient temperatures), and should not be used outside this range. The climate range for your appliance is stated on the data plate inside the appliance.

Installing it in a room with too low an ambient temperature, e.g. a garage, can lead to the appliance switching off for longer periods so that it cannot maintain the required temperature.

▶ Do not place electric heaters or candles in the appliance to defrost it. These can damage the plastic parts.

▶ Do not use defrosting sprays or de-icers, as they might contain substances which could damage the plastic parts or which could cause a build-up of gases and pose a danger to health.

▶ Do not use a steam-cleaning appliance to defrost or clean this appliance. Steam could reach the electrical components and cause a short circuit.

## Stainless steel appliances

▶ Do not use sticky notes, transparent adhesive tape, masking tape or other types of adhesive on the surface of the door.

These damage the surface, causing it to lose its dirt repellent protective coating.

▶ The high-quality surface of the door is susceptible to scratching. Even fridge magnets can cause scratching.

## Disposal of your old appliance

▶ Before disposing of an old appliance, first make the door latch or lock unusable.

This way you will prevent children from accidentally locking themselves in and endangering their lives.

▶ Be careful not to damage any part of the pipework whilst awaiting disposal, e.g. by

- puncturing the refrigerant channels in the evaporator.
- bending any pipework.
- scratching the surface coating.

Splashes of refrigerant can damage the eyes.

The manufacturer cannot be held liable for damage caused by non-compliance with these Warning and Safety instructions.

# How to save energy

	<b>Normal energy consumption</b>	<b>Increased energy consumption</b>
<b>Installation site</b>	In a ventilated room.	In an enclosed, unventilated room.
	Protected from direct sunlight.	In direct sunlight.
	Not near to a heat source (radiator, oven).	Near to a heat source (radiator, oven).
	Where the ideal ambient room temperature is approx. 20°C.	Where there is a high ambient room temperature.
	Do not cover the ventilation gaps and dust them regularly.	
<b>Temperature setting with a thermostat which is approximate (set in stages).</b>	With a medium setting of 2 to 3.	With a high setting: the lower the temperature in the compartment, the higher the energy consumption.
<b>Temperature setting with a thermostat which is exact to the degree (digital display).</b>	Larder section 8 to 12 °C	On appliances with winter setting, please make sure that the winter setting is switched off when the ambient temperature is warmer than 16 °C .
	Refrigerator section 4 to 5 °C	
	PerfectFresh zone just above 0 °C	
	Freezer section -18 °C	
	Wine storage section 10 to 12 °C	
<b>Use</b>	Drawers, shelves and racks arranged as they were when the appliance was delivered.	
	Only open the door when necessary and for as short a time as possible.	Frequent opening of the door for long periods will cause a loss of coldness.
	Store food in an organised way.	Searching for an item will mean the door is open for longer.
	Allow hot food and drinks to cool down before placing them in the appliance.	Hot food will cause the compressor to run for a long time, as the appliance will have to work harder to reduce the temperature.
	Store food covered or packaged.	The evaporation or condensation of liquids will cause a loss of coldness in the refrigerator.
	Place frozen food in the refrigerator to defrost.	
	Do not over-fill the appliance to allow air to circulate.	
<b>Defrosting</b>	Defrost the freezer section when a layer of ice 0.5 cm thick (maximum) has built up.	A layer of ice hinders the cold from reaching the frozen food, and increases energy consumption.

# Switching on and off

---

## Before using for the first time

### Protective foil

On stainless steel appliances, the stainless steel door (and sides, depending on model) have a layer of protective foil to prevent damage during transportation.

- Do not remove this foil until the appliance has been positioned in its final location.

### Cleaning

- Clean the inside of the appliance and the accessories with lukewarm water and a little washing-up liquid, and then dry with a soft cloth.

## Switching on

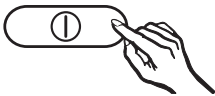

- Press the On/Off button.

The temperature display and the alarm indicator light will flash until the freezer has cooled down to the correct temperature for freezing.

To enable the temperature to get sufficiently cold inside the appliance, allow it to run for a few hours until it has reached  $-18\text{ }^{\circ}\text{C}$  before placing food in it.

## Switching off

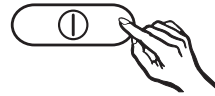

- Press the On/Off button until the temperature display goes out.

All the displays will go out and the cooling system will switch off.

## Switching off for longer periods of time

If the appliance is not going to be used for a longer period of time, e.g. whilst on holiday:

- switch the appliance off,
- disconnect it from the mains. Switch off at the wall and withdraw the plug from the socket, or disconnect the mains fuse.
- clean the appliance out and
- leave the door ajar to air the appliance.

If, during a long absence, the appliance is switched off but not cleaned out and the door is left shut, there is a danger of mould and odours building up inside the appliance.

# The correct temperature

It is very important to set the correct temperature for storing food in the appliance. Micro-organisms will cause food which is not stored at the correct temperature to deteriorate rapidly. Temperature influences the growth rate of these micro-organisms. Reducing the temperature reduces their growth rate.

To freeze fresh food and to store frozen food for a long time, a temperature of **-18 °C** is required. At this temperature the growth of micro-organisms is generally halted. As soon as the temperature rises above -10 °C, the micro-organisms become active in the food again so that it cannot be kept as long. For this reason, partially defrosted or defrosted food must not be re-frozen. Food may be re-frozen once it has been cooked, as the high temperatures achieved when cooking destroy most micro-organisms.

The temperature in the appliance will rise:

- the more often the door is opened and the longer it is kept open,
- if too much food is stored in it at once,
- if too much fresh food is being frozen at once,
- the higher the ambient temperature surrounding the appliance.

The appliance is designed for use in specific ambient temperatures (climate ranges). Do not use in ambient temperatures for which it is not designed.

## Setting the temperature

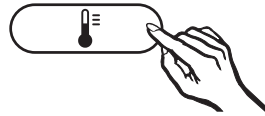

- Press the temperature button repeatedly until the indicator light for the temperature you want lights up in the display.

The temperature value will change until the setting for -32 °C is reached. It will then go back to the -15 °C setting.

The temperature can be set slightly colder within the displayed temperature (e.g. between -15°C and -18°C).

- Press the temperature button repeatedly until the indicator light for -15 °C lights up in the display.
- Press it again for approx. 5 seconds to set the temperature below -15°C.

The colder temperature setting within the small temperature range is now set. However, this is not visible in the temperature display.

# The correct temperature

---

## Temperature display

The temperature display on the control panel always shows the **required** temperature.

The temperature can be adjusted from:  
-15 °C to -32 °C

The **temperature display will flash** if

- the temperature in the appliance is not within the possible temperature range,
- a different temperature is being set,
- the temperature in the appliance has risen by several degrees, indicating that the appliance is warming up too much.

This loss of coldness is no cause for concern in the following circumstances:

- when the door has been left open for a while, e.g. for removing or storing a large amount of food,
- when fresh food is being frozen.

However, if the temperature in the freezer remains above -18 °C for a long time, check that the frozen food has not started to defrost. If it has started thawing, check that the food is safe to use and if it is, use it as quickly as possible.

Your appliance has been fitted with a warning system which ensures that the temperature in the freezer cannot rise unnoticed. An alarm will sound, and the temperature display and the alarm indicator light will flash if the temperature becomes too warm.

The temperature the appliance is set at determines the temperature the appliance recognises as being too warm.

For example, the alarm may sound and the alarm indicator light may flash,

- After a power cut.
- If you freeze a large amount of food at once without having switched on the Super freeze function beforehand.
- If the door has been left open for too long whilst taking food out or rearranging it and let warm room air into the freezer.

Depending on the temperature in the freezer, you should check the condition of the food. If food has defrosted or started to defrost, check that it is still safe to use, and if so, use it as quickly as possible. Defrosted food may only be re-frozen after it has been cooked.

## Activating the alarm system

The alarm system is always active. It does not have to be switched on manually.

## Switching the alarm off early

The alarm will stop and the indicator light will go out when the temperature reaches the correct level again.

However, if the noise disturbs you, you can switch the alarm off before this if you wish.

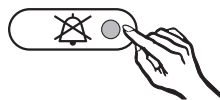

- Press the alarm off button.

The alarm will stop.

The indicator light will stay on until the correct temperature has been reached. The alarm system is then ready should it be needed again.

# Super freeze

---

Switch the Super freeze function on before putting fresh food into the freezer.

This helps food to freeze quickly and retain its nutrients, vitamins, flavours and appearance.

## Super freeze is not necessary:

- when putting in food that is already frozen.
- when freezing up to 2 kg fresh food daily.

## Switching on Super freeze

When freezing small quantities of food in the freezer, the Super freeze function should be switched on **6 hours beforehand**. When freezing **the maximum load of food** the Super freeze function should be switched on **24 hours beforehand**.



- Press the Super freeze button. The Super freeze indicator light will come on.

The appliance works at full power to lower the temperature in the appliance.

## Switching off Super freeze

The Super freeze function will switch off automatically after approx. 65 hours. The indicator light will go out and the appliance will run at normal power again.

To save energy, the Super freeze function can be switched off once a **constant** temperature of  $-18^{\circ}\text{C}$  or colder has been reached in the freezer. You should also check the temperature inside the appliance from time to time.

- Press the Super freeze button. The Super freeze indicator light will go out, and the appliance will continue to operate at normal power.



## Maximum freezing capacity

To ensure that fresh food placed in the freezer freezes through to the core as quickly as possible, the maximum freezing capacity must not be exceeded. The maximum freezing capacity for freezing within a 24-hour period is given on the data plate: "Freezing capacity ....kg/24 hrs".

The maximum freezing capacity given on the data plate has been calculated according to DIN EN ISO 15502 Standard.

## Freezing fresh food

Fresh food should be frozen as quickly as possible. This way the nutritional value of the food, its vitamin content, appearance and taste are not impaired.

Food which takes a long time to freeze will lose more water from its cells, which then shrink.

During the defrosting process, only some of this water is reabsorbed by the cells; the rest collects around the food.

In practice this means that the food loses a large degree of its moisture. You can tell if this has happened by the amount of liquid around the food.

If food is frozen quickly, the cells have less time to lose moisture, so they shrink less. As there is not so much moisture loss, it is easier for the food to reabsorb it during the defrosting process, and very little water collects around the defrosted food.

## Isolation plate

(depending on model, available as an optional accessory)

The isolation plate is used to isolate freezer drawers which you do not wish to use, and thus save energy. It should be used if only small amounts of food are being stored in the freezer.

## Important

- At least 3 freezer drawers as well as the freezer tray must be used for freezing food.

The other drawers can be isolated if they are not needed. However, no fewer than the two bottom drawers can be isolated.

- The drawers being used for freezing must always be at the top of the freezer.
- The isolation plate must be fitted **below** the lowest drawer in which food is being frozen.
- The fewer drawers you use, the more energy you will save. Using the isolation plate increases energy savings considerably.

# Freezing and storing food

Do not store food in the "inactive" drawers. The temperature is not controlled in these drawers and food stored in them would soon deteriorate.

## Example

If you only require 3 freezer drawers as well as the freezer tray for storing frozen food:

- Place food in the top 3 freezer drawers, leaving the other drawers empty.
- Remove the fourth drawer and keep it somewhere else.

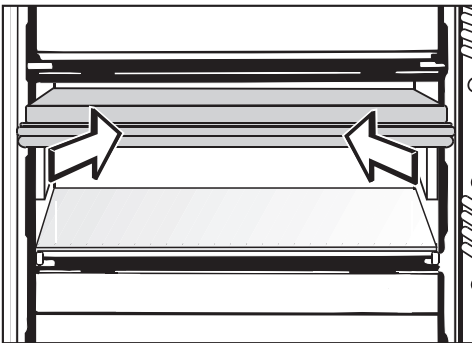

- Slide the isolation plate in **underneath** the third drawer.

This "switches off" (isolates) the drawers below.

## Storing frozen food

When buying frozen food to store in your freezer, check

- that the packaging is not damaged,
  - the use-by date,
  - the temperature at which the frozen food is being stored in the shop. The length of time it can be kept is reduced if it has been stored at a temperature warmer than  $-18^{\circ}\text{C}$ .
- Buy frozen food once you have finished the rest of your shopping, and wrap it in newspaper or use a cool bag or cool box to transport it.
  - Store it in the freezer as soon as possible.

Never re-freeze partially or fully defrosted food. Consume defrosted food as soon as possible as it will lose its nutritional value and spoil if left for too long. Defrosted food may only be re-frozen after it has been cooked.

## Home freezing

Only freeze fresh food which is in a good condition.

### Hints on home freezing

- The following types of food **are suitable** for freezing:  
Fresh meat, poultry, game, fish, vegetables, herbs, fresh fruit, dairy products, pastry, leftovers, egg yolks, egg whites and a range of pre-cooked meals.
- The following types of food **are not suitable** for freezing:  
Grapes, lettuce, radishes, sour cream, mayonnaise, eggs in their shells, onions, whole raw apples and pears.
- To retain colour, taste and vitamin C, vegetables should be blanched after they have been trimmed and washed.  
To blanch: bring a large saucepan of water to the boil, immerse the vegetables in the fast boiling water for 2-3 minutes, depending on variety. Remove, and plunge into ice-cold water to cool quickly. Drain and pack ready for freezing.
- Lean meat freezes better than fatty meat, and can be stored for considerably longer.
- To prevent chops, steaks, cutlets or rolled meat from freezing together in solid blocks when packed, separate with a sheet of plastic freezer film.
- Do not season fresh foods or blanched vegetables before freezing. Only season cooked food

lightly before freezing, but care should be taken as the taste of some spices alters when frozen.

- Do not place hot foods or drinks in the freezer. This causes already frozen food to thaw, and increases the energy consumption considerably. Allow hot foods and drinks to cool down before placing them in the freezer.

### Packing

- Freeze food in portions.

#### Unsuitable packing material

- wrapping paper
- grease-proof paper
- cellophane
- bin bags
- plastic carrier bags

#### Suitable packing material

- plastic freezer film
- freezer bags
- aluminium foil
- freezer containers

- Expel as much air as possible from bags etc. before sealing them, to prevent freezer-burn on food.
- Close the packaging tightly with
  - rubber bands
  - plastic clips
  - string or bag ties
  - freezer tape.

Freezer bags may also be sealed using home heat sealing kits.

- Make a note of the contents and the date of freezing on the packaging.

# Freezing and storing food

## Before placing food in the freezer

- When freezing more than 2 kg of fresh food, switch on the Super freeze function for some time before placing the food in the freezer (see "Super freeze").

This helps food that is already in the freezer to stay frozen.

## Placing food in the freezer

The following maximum capacities must be observed:

- top freezer drawer = 15 kg
- all other freezer drawers = 25 kg
- glass cold plate = 35 kg

Food to be frozen must on no account touch food which is already frozen to avoid partial thawing.

- Make sure that the packaging and containers are dry to prevent them sticking together when frozen.

### – Freezing small portions

Place the food in the lower freezer drawers.

- Place the food flat in the bottom of the drawers so that it freezes through to the core as quickly as possible.

Please note that when removing drawers, the lowest freezer drawer must always remain in the freezer. When placing food on the glass cold plate make sure it does not obstruct the ventilation gaps at the back. This is important for problem-free operation and normal energy consumption

### – Freezing the maximum amount (see data plate)

- Remove the freezer drawers.
- Place the food flat on the bottom of the lower glass cold plates so that it freezes through to the core as quickly as possible.

### – Large items

If you wish to freeze large items such as a turkey or game, the glass cold plates between the drawers can be removed.

- Remove the freezer drawers and carefully lift and slide out the glass cold plates.

# Freezing and storing food

## Defrosting

Frozen food can be defrosted in different ways:

- in a microwave oven,
- in an oven using the "Fan" or "Defrost" setting,
- at room temperature,
- in the refrigerator (the cold given off by the frozen food helps to keep other food cold),
- in a steam oven.

**Poultry** It is particularly important to observe food hygiene rules when defrosting poultry. Do not use the liquid from defrosted poultry. Pour it away and wash the container it was in, the sink and your hands. Danger of salmonella poisoning.

Ensure that **meat and fish** (e.g mince, chicken, fish fillets) do not come into contact with other foods when thawing. Collect the liquid and dispose of it carefully.

**Fruit** should be defrosted at room temperature in its packaging, or in a covered bowl.

**Most vegetables** can be cooked while still frozen. Just put straight into boiling water or hot fat. The cooking time is slightly less than that of fresh vegetables due to changes in the cell structure.

Never re-freeze partially or fully defrosted food. Consume defrosted food as soon as possible as it will lose its nutritional value and spoil if left for too long. Defrosted food may only be re-frozen after it has been cooked.

## Ice cubes

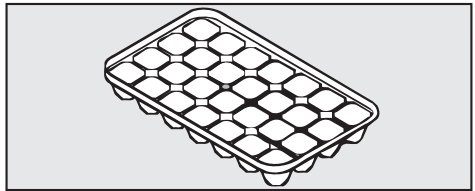

- Fill the ice tray three quarters full with water and place it on the bottom of one of the freezer drawers.
- Once frozen, use a blunt instrument, for example a spoon handle, to remove the ice tray from the freezer.
- Ice cubes can be removed easily from the tray by twisting the tray gently or by holding it under cold running water for a short while.

## Cooling drinks

Do not store cans or bottles containing carbonated drinks or liquids which could freeze in the freezer. The cans or bottles could explode.

When cooling non-carbonated drinks quickly in the freezer, make sure bottles are not left in **for more than one hour**, otherwise they could burst.

# Freezing and storing food

---

## Freezer tray

The freezer tray is useful for freezing small items such as berries and vegetables. They can be frozen individually and therefore maintain their shape when defrosted.

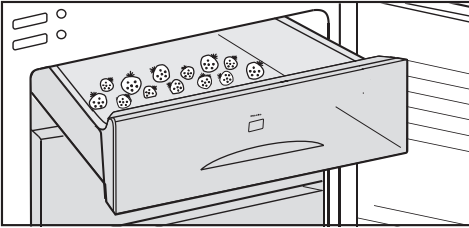

- Space the food out loosely on the tray.

Leave the food for 10-12 hours to freeze thoroughly on the tray. Transfer it to a freezer bag or suitable container once frozen. Place the bag or container in the freezer drawer.

This freezer is equipped with a Frost free system. The freezer defrosts automatically.

The moisture generated by defrosting settles on the condenser and is automatically dissipated from time to time.

This automatic defrosting system enables the freezer to remain permanently ice-free, however, the food stored in the freezer will not defrost.

# Cleaning and care

---

A range of Miele branded cleaning and conditioning products is available to order from Miele or [www.miele-shop.com](http://www.miele-shop.com).

Make sure that no water can penetrate into the electronic unit or into the ventilation gaps.

Do not use steam cleaning apparatus to clean the appliance. Steam could reach the electrical components and cause a short circuit.

The data plate located inside the appliance must not be removed. It contains information which is required in the event of a service call.

## To avoid damaging the surface of your appliance, do not use:

- cleaning agents containing soda, ammonia, acids or chlorides,
- cleaning agents containing descaling agents,
- abrasive cleaning agents, e.g. powder cleaners and cream cleaners,
- solvent-based cleaning agents,
- stainless steel cleaning agents,
- dishwasher cleaner,
- oven sprays,
- glass cleaning agents,
- hard, abrasive sponges and brushes, e.g. pot scourers,

- melamine eraser blocks,
- sharp metal scrapers.

## Before cleaning

- Switch the appliance off.
- Disconnect it from the mains.
- Take any frozen food out of the appliance and store it in a cool place.
- Take the freezer drawers and the glass cold plates out of the freezer to clean them.

## Cleaning the interior and accessories

- Use lukewarm water with a little washing-up liquid.

The ice tray is dishwasher safe.

The temperature of the dishwasher programme must not exceed 55 °C. Contact with some foodstuffs, such as carrots, tomatoes or ketchup can cause plastic items to discolour. However, this discolouration will not affect the stability of plastic items.

- Clean the drawers and glass cold plates by hand. These are **not** suitable for cleaning in a dishwasher.
- After cleaning, wipe the interior and accessories with a damp cloth and dry with a soft cloth. Leave the door open to air the appliance for a short while.



## Appliance door, side panels

Remove any soiling from the appliance door and side panels immediately.

If this is not done, it might become impossible to remove and could cause the surface to alter or discolour.

All surfaces are susceptible to scratching.

Contact with unsuitable cleaning agents can alter or discolour the surfaces.

- The surfaces should be cleaned using a solution of hot water and a little washing-up liquid applied with a soft sponge. They can also be cleaned with a damp microfibre cloth (without using any cleaning agent).
- After cleaning, wipe with a damp cloth and dry with a soft cloth.

## Stainless steel appliance door:

The appliance door has a high quality, special finish which is resistant to soiling and is very easy to clean.

**Do not use** the following to clean/condition the door

- stainless steel cleaning agent: this will damage the surface.
- Miele stainless steel conditioning agent: this will cause noticeable smearing.

## Ventilation gaps

- The ventilation gaps should be cleaned regularly with a brush or vacuum cleaner. A build-up of dust will increase the energy consumption of the appliance.

## Door seal

Do not use any oils or grease on the door seal as these will cause the seal to deteriorate and become porous over time.

- The door seal should be cleaned regularly with clean water and then wiped dry with a soft cloth.

## Cleaning and care

---

### Metal grille at the back of the appliance

The metal grille at the back of the appliance (heat exchanger) should be dusted at least once a year. A build-up of dust will increase the energy consumption of the appliance.

When cleaning the metal grille, make sure that the pipework and other components do not get broken or damaged in any way.

### After cleaning

- Replace all shelves and accessories in the appliance.
- Close the appliance door.
- Insert the plug in the socket and switch on at the mains. Then switch the appliance back on.
- Switch on the Super freeze function so that the appliance can cool down quickly.
- Once the temperature in the freezer has reached the required temperature, place the food back in the freezer drawers and put them back in the freezer.
- Switch off the Super freeze function as soon as the temperature in the freezer is a constant -18 °C or colder.

Repairs to electrical appliances should only be carried out by a suitably qualified and competent person in strict accordance with current local and national safety regulations. Repairs and other work by unqualified persons could be dangerous. The manufacturer cannot be held liable for unauthorised work.

### What to do if . . .

#### **. . . the appliance does not get cool.**

- Check whether the appliance has been switched on. The temperature display must be lit up.
- Check that the plug is correctly inserted into the socket and switched on.
- Check that the fuse is not defective and the mains fuse has not tripped. If it has there could be a fault with the household electrical wiring, the freezer or another electrical appliance. Contact a qualified electrician or Miele.

#### **. . . the door will not open because it has been opened and closed too many times in succession.**

This is not a fault. The suction caused by opening and closing the door is preventing the door from opening. Wait a few minutes and then try again. It should now open without force.

#### **. . . the temperature inside the appliance is too low.**

- Turn the temperature to a higher setting.
- Super freeze has not yet switched itself off. The Super freeze function switches itself off automatically after approx. 65 hours.

#### **. . . the appliance is switching in too frequently and for too long.**

- Check whether the ventilation gaps have been covered over or become dusty.
- Check whether the metal grille (heat exchanger) at the back of the appliance has become too dusty.
- The door has been opened too frequently, or a large amount of fresh food has been put in at once for freezing.
- Check that the door has been closed properly.

#### **. . . the compressor runs continuously.**

To save energy, the compressor runs at a lower speed, but for longer, when less cooling is required.

# Problem solving guide

---

## **. . . the alarm sounds and the alarm indicator light flashes.**

The temperature in the freezer is too warm, because

- The door has been opened too frequently.
- A large amount of food has been frozen at once without switching on the Super freeze function.
- There has been a lengthy interruption to the power supply.

The alarm will stop and the indicator light will go out when the temperature has reached the correct level again.

Depending on the temperature in the freezer, you should check the condition of the food. If food has defrosted or started to defrost, check that it is still safe to use, and if so, use it as quickly as possible. Defrosted food may only be re-frozen after it has been cooked.

## **. . . the Super freeze indicator light and the temperature display are both flashing at the same time.**

There is a fault. Call the Service Department.

## **. . . the Super freeze indicator light does not light up, even though the appliance is working.**

- The indicator light is defective. Call the Service Department.

## **. . . food has frozen together.**

Use a blunt instrument, e.g. a spoon handle or plastic scraper, to prise it apart carefully.

## **. . . there is a build-up of frost on the front panel of the frost-free system.**

This is not a fault. Droplets of condensate have settled on it and frozen. This may have been caused by one of the following:

- The appliance door has been opened frequently or left open for a while.
- A large quantity of fresh food has been placed in the appliance at once.
- There has been an increase in the humidity in the room.

Keep the door closed as much as possible so that the Frost Free system has a chance to melt the ice automatically. This may take several days.

If you still cannot remedy the fault having followed these suggestions, please contact the Miele Service Department.

To prevent unnecessary loss of temperature it is advisable not to open the door while waiting for the appliance to be serviced.

Normal noises	What causes them
<b>Brrrrr...</b>	Humming noise made by the motor (compressor). This noise can get louder for brief periods when the motor is switching on.
<b>Blubb, blubb....</b>	A gurgling noise can be heard when coolant is circulating through the pipes.
<b>Click....</b>	Clicking sounds are made when the thermostat switches the motor on and off.
<b>Sssrrrrr....</b>	On multi-zone and frost-free appliances you can sometimes just hear the movement of air circulating inside the appliance.
<b>Creak ...</b>	Creaking sounds can be heard when material inside the appliance expands.

Remember that the noise of the compressor and the coolant circulating in the system is unavoidable.

Noises that you can easily rectify	What causes them, and what can you do about them
<b>Rattling, vibrating</b>	<b>The appliance is uneven:</b> Realign the appliance using a spirit level, by raising or lowering the screw feet underneath the appliance.
	<b>The appliance is touching another appliance or piece of furniture:</b> Move it away.
	<b>Drawers, baskets or shelves are unstable or sticking:</b> Check all removable items and refit them correctly.
	<b>Are any bottles or containers unstable or knocking against each other?</b> Separate them.
	<b>The transport cable clips are hanging loose at the back of the appliance:</b> Remove the clips.

## After Sales / Guarantee

---

In the event of a fault which you cannot correct yourself, or if the appliance is under guarantee, please contact:

– your Miele Dealer

or

– Miele  
(see back cover for contact details).

When contacting your Dealer or Miele, please quote the model and serial number of your appliance. This information is given on the data plate inside your appliance.

Please note that telephone calls may be monitored and recorded for training purposes.

N.B. A call-out charge will be applied for service visits where the problem could have been resolved as described in these instructions.

### **Guarantee**

For information on the appliance guarantee specific to your country please contact Miele. See back cover for contact details.

In the U.K. your appliance is guaranteed for 2 years from the date of purchase. However, you must activate your cover by calling 0845 365 6640 or registering online at [www.miele.co.uk](http://www.miele.co.uk).

## Electrical connection U.K.

All electrical work should be carried out by a suitably qualified and competent person in strict accordance with current local and national safety regulations (BS 7671 in the UK).

The appliance is supplied with a mains cable and moulded plug ready for connection to an a.c. single phase 220-240 V 50 Hz supply.

Please ensure that the connection data quoted on the data plate match the household mains supply.

Connection should be made via a suitable switched socket which is easily accessible. For extra safety it is advisable to protect the appliance with a suitable residual current device (RCD).

Do not connect the appliance to the mains electricity supply by an extension lead. Extension leads do not guarantee the required safety of the appliance (e.g. danger of overheating).

This appliance must not be connected to the inverter of an autonomous power supply, e.g. a solar power system. When switching the appliance on, a surge in power could trigger the safety cut-out mechanism. This could damage the electronic unit.

The appliance must not be used with so-called energy saving devices. These reduce the energy supply to the appliance which could then become too warm. Using such devices could alter the specification of the product.

## Non-rewireable plugs (BS 1363)

The fuse cover must be re-fitted when changing the fuse, and if the fuse cover is lost, the plug must not be used until a suitable replacement is obtained. The colour of the correct replacement cover is that of the coloured insert in the base of the plug, or the colour that is embossed in words in the base of the plug (as applicable to the design of the plug fitted).

Replacement fuses should be ASTA approved to BS 1362 and have the correct rating. Replacement fuses and fuse covers may be purchased from your local electrical supplier.

**WARNING**  
**THIS APPLIANCE MUST BE**  
**EARTHED**

# Installation

Do not place any appliance which gives off heat, such as a toaster or microwave oven, on top of this appliance, as this would increase the appliance's energy consumption.

This appliance has side-wall heating and can be installed side-by-side with another refrigeration appliance. Please ask your supplier for details of suitable appliances.

## Location

This appliance should be installed in a dry, well-ventilated room. It should not be installed where it is exposed to direct sunlight or directly adjacent to a heat-producing appliance such as an oven or a radiator. The room temperature should not go above or below the climate range for which the appliance is designed. The higher the ambient temperature of the room, the more energy the appliance requires to operate.

## Important: tropical / humid environments

During periods of high humidity, some condensation may appear on outside surfaces of cooling appliances. This condensation will disappear when humidity levels drop. For prevention, it is advisable to install the appliance with sufficient ventilation in a dry and/or an air-conditioned room. Please ensure that doors are closing and sealing properly. Please ensure that the appliance is installed in accordance with these installation instructions and that the handle is fitted correctly. Should you require further assistance please contact your Miele customer service centre.

## Climate range

The appliance is designed for use within certain climate ranges (ambient temperatures), and should not be used outside this range. The climate range of the appliance is stated on the data plate inside the appliance.

Climate range	Ambient room temperature
SN	+ 10 to +32 °C
N	+16 to +32 °C
ST	+16 to +38 °C
T	+16 to +43 °C

Operating in a room which is too cold will result in the cooling system switching off for too long, causing the internal temperature in the appliance to rise with the risk of frozen food deteriorating and going off.



## Ventilation

Air at the back of the appliance gets warm. To ensure sufficient ventilation, the air inlet and outlet must not be covered or blocked in any way. They should be dusted on a regular basis.

## Installation

- Remove the cable clip from the back of the appliance.
- Check that all parts at the back of the appliance are unhindered. Carefully remove any hindrance.
- Carefully push the appliance into position with the back against the wall.

## Aligning the appliance

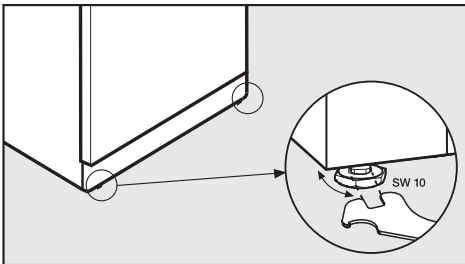

- To align the appliance, adjust the feet using the spanner supplied.

## Levelling the appliance door

(depending on model)

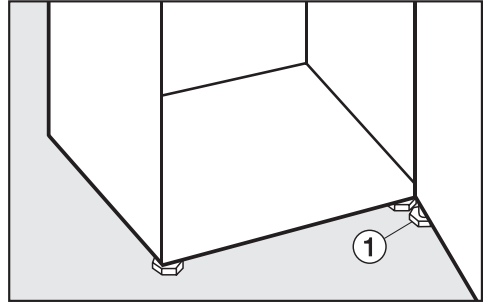

- **Ensure** that you unscrew adjusting foot ① from the hinge plate until it sits on the floor. Then unscrew the foot by a further 90°.

# Installation

---

## Appliance dimensions

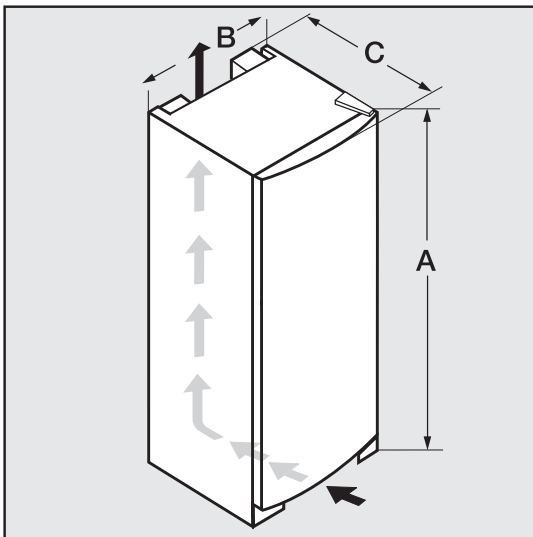

	<b>A</b>	<b>B</b>	<b>C</b>
<b>FN 11827 S</b>	1850 mm	600 mm	630 mm
<b>FN 12827 S</b>			
<b>FN 12827 S edt/cs</b>			

# Installing in a side-by-side combination

To avoid a build-up of condensation and resultant damage, refrigerators and freezers should not normally be installed side-by-side.

However, this appliance has side wall heating, and can be installed side-by-side with certain other Miele appliances.

Your dealer will be able to advise you on which models are suitable.

## Installing the appliances

Two people are needed to install the appliances side-by-side.

Warning. Risk of damage when moving the appliances once they have been joined together as they are very heavy.

Moving them incorrectly can cause dents. Carefully observe the instructions on how to move the appliances.

- The freezer or fridge-freezer must be installed to the left of any refrigerator when viewed from the front. The side wall heating in the right-hand wall of the freezer or fridge-freezer is insulated to prevent the build-up of condensation between the two appliances.
- To move the appliances always hold them by the outer front corners.
- Place the two appliances as close as possible to their final position so that they can be aligned for any unevenness in the floor. The back of the appliances still needs to be kept accessible to complete the installation.

## Instructions for moving the appliances once they have been joined

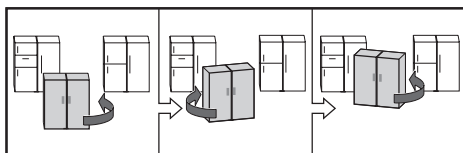

- Push the left and then the right corners alternately.

### – If the joined appliances are directly in front of the niche:

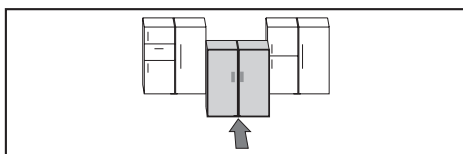

- Carefully push the two appliances back into their final position.

### – If the joined appliances have to be taken out of their niche:

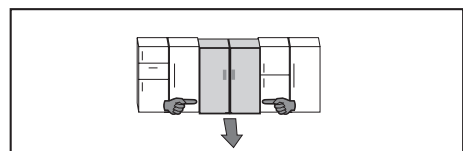











- Hold the bottom third section and pull the appliances straight forwards.

# Installing in a side-by-side combination

## Joining the two appliances together

The following fixing parts are supplied:

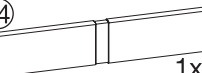
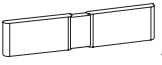
①	 4x		
③	 1x	④	 M5x30 Torx® 25 4x
⑦	 1x	⑧	 M5x30 Torx® 25 4x
⑨	 1x	⑩	 1x
		⑪	 M5x7 Torx® 25 1x
⑫	 1x		
⑬	 1x		
⑭	 1x		
⑮	 1x		

\* Colour depending on model (the other colour variations are not needed)

The following tools are supplied:

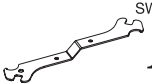
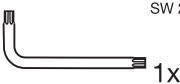
⑱	 SW 10 1x	⑳	 SW 2 1x
---	--	---	---

⑱ SW 10 spanner

⑳ SW2 allen key  
(not required)

You will also need the following:

- Spirit level
- Cordless screwdriver
- Torx® 25 screwdriver

- Before starting, peel off any protective foil from the appliance casing.

## Installation steps at the front of the appliances

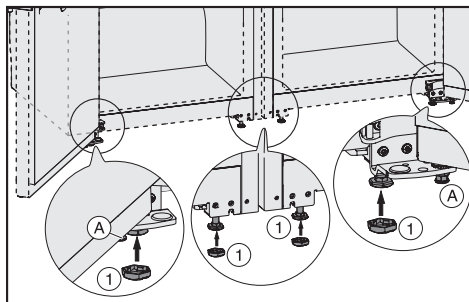

- Use spanner ⑱ supplied to screw in feet (for supporting the appliance doors) ① completely. They must not come in contact with the floor.
- Fit covers ① to the four front feet.

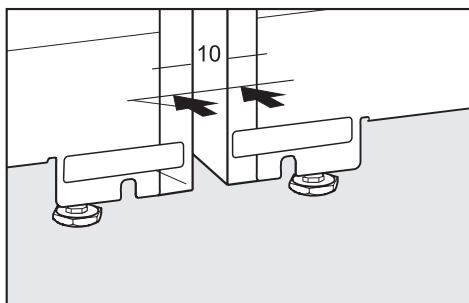

- Place the appliances next to one another so that the fronts are aligned, leaving a gap of 10 mm between them.

## Installing in a side-by-side combination

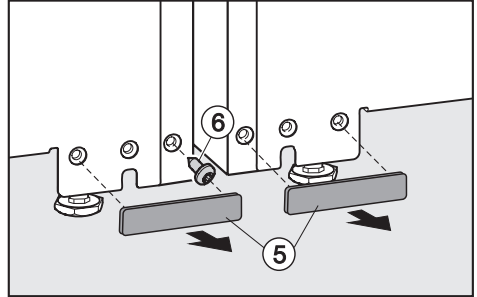
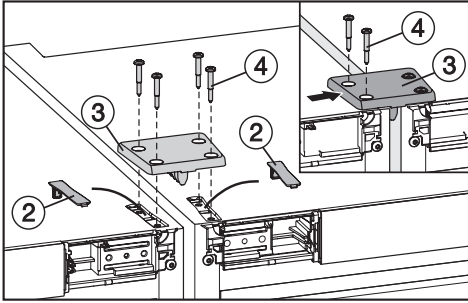

- Remove covers ② at the top.

Attaching the connecting plate will align the appliances in height and depth. If one of the appliances is higher than the other, start with the higher appliance:

- Loosely screw connecting plate ③ to one of the appliances using two screws ④.
- Push connecting plate ③ until the middle ridge of the plate touches the side of the appliance.
- Now tighten both screws ④.
- Secure connecting plate ③ to the other appliance. To do this push the appliances together or apart a little, as necessary.

- Remove the two covers ⑤ from the bottom of the appliances.
- Remove screw ⑥, if present. This screw is no longer required.

# Installing in a side-by-side combination

Attaching the connecting panel will align the appliances in depth. If one of the appliances protrudes further forward than the other, start with the further forward appliance:

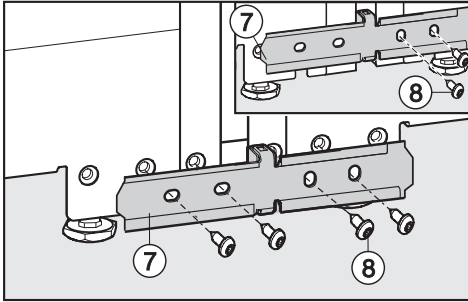

- Place the connecting panel (7) so that the vertical slots are on the side of the panel which will be attached to an appliance first. Attach it loosely with two screws (8).
- Push connecting panel (7) until the central stay on the bracket touches the side of the appliance.
- Now tighten both screws (8).
- Secure connecting panel (7) to the other appliance. To do this push the appliances together a little, as necessary.

## Installation steps at the back of the appliances

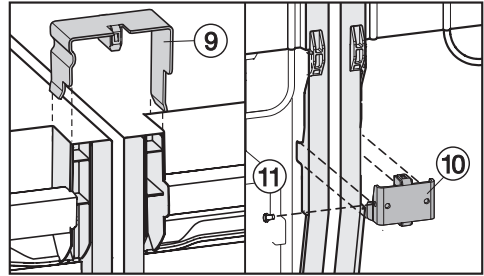

- Fit connecting bracket (9) onto the top of the sides in the middle.
- Fit connecting piece (10) into the relevant gap below.
- Tighten connecting piece (10) using screw (11) supplied.  
Warning: Do not drill a hole in the appliance for this screw.

To avoid vibrations, the connecting bracket, connecting piece and screw must not touch the pipework at the back of the appliances.

# Installing in a side-by-side combination

## Installation steps at the front of the appliances

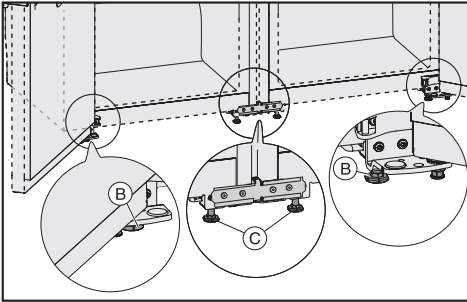

- Screw in middle feet © completely. They must not come in contact with the floor.
- Align the joined appliances using outer feet ②.

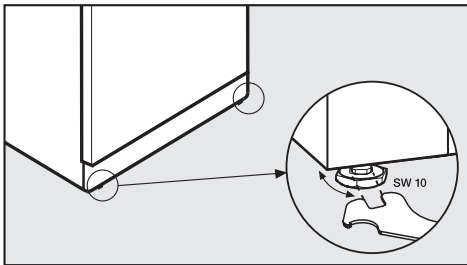

- Align the feet using the spanner supplied.

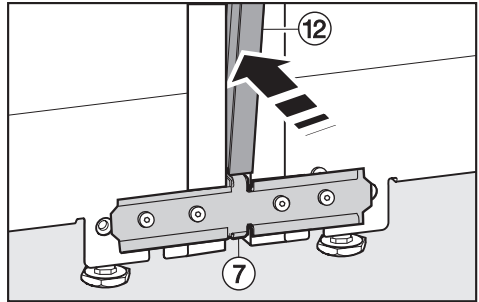

- Position the front of the long stainless steel trim ⑫ in the gap, making sure that it is located above connecting panel ⑦.

Pressing both ridges along the trim together as you do so makes it easier to fit the trim into the gap.

- Carefully work stainless steel trim ⑫ into the gap. Use a soft cloth to do this to avoid denting the trim.
- Carefully remove the protective foil from the stainless steel trim.

## Installing in a side-by-side combination

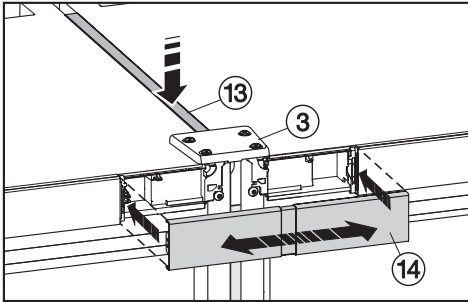

- Push short trim ⑬ into the gap at the top of the appliances. Make sure that the front edge of the trim sits flush up against the edge of connecting plate ③.
- Fit cover ⑭ between the control panels. Make sure that the outer edges of the cover are flush with the control panels. The cover can be pulled out to adjust it to the right size.

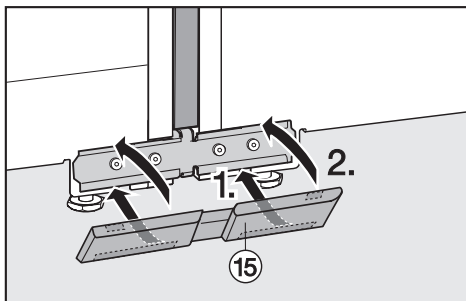

- Fit cover ⑮ to the bottom of the fronts of the appliances.

- Connect both appliances to the electricity supply as described in the operating instructions supplied with the appliances.
- Appliances with an ice cube maker: Connect the appliance to the mains water supply as described in the operating instructions supplied with it.

Warning. Risk of damage when moving the appliances once they have been joined together as they are very heavy. Moving them incorrectly can cause dents. Carefully observe the instructions on how to move the appliances.

- Carefully push the two appliances back into their final position.
- If necessary align the height of the appliances again using outer feet ②.
- Unscrew middle feet ③ until they are on the floor.
- Support the appliance doors with foot ① on the hinge plate: Unscrew foot ① until it sits on the floor. Then unscrew the foot by a further 90°.

Align the handles on both doors, if necessary. See "Changing the door hinging".



## To change the door hinging you will need the following tools:

- a cross-slotted screwdriver,
- a flat-bladed screwdriver,
- a selection of Torx screwdrivers,
- a spanner.

Two people are needed for changing the door hinging.

## Removing the door handle

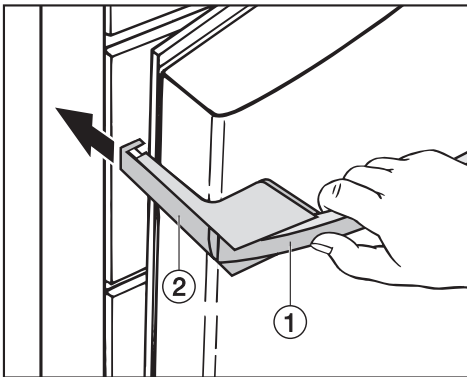

- Pull door handle ① towards you. Side section ② slides back.
- Pull side section ② firmly back out of the guides on the mounting plate.
- Undo the 4 screws (Torx 15) in the mounting plate, and remove the handle.
- Remove the cover caps from the opposite side, and fit them into the empty holes.

# Changing the door hinging

## Changing over the door

- Close the appliance door.

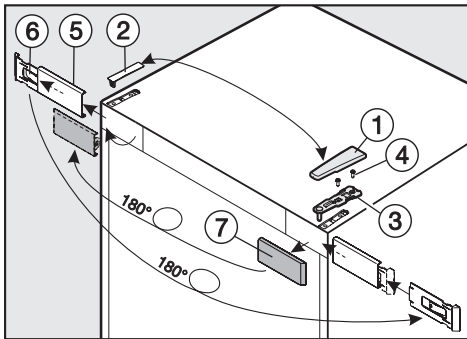

- Remove cover ① by sliding it forwards from the back and then lifting it off.
- Remove cover ② by pulling it upwards.

Caution. The appliance door is not secure once the hinge plate has been removed.

- Loosen screws ④ in upper hinge plate ③ and pull it upwards and off.
- Carefully lift the door off and place it to one side.
- Carefully ease off cover ⑤ from above using a screwdriver and then take it off together with retaining plate ⑥.
- Then separate retaining plate ⑥ from cover ⑤, by pushing it slightly to the left and then pulling the cover forwards and off.
- Rotate retaining plate ⑥ by 180°.
- Then fit cover ⑤ from the front over retaining plate ⑥, and slide it over to the right. The writing must be visible.

- Remove cover ⑦, then rotate it by 180° and fit it on the opposite side.
- Then fit cover ⑤ together with retaining plate ⑥ on the opposite side.



## Changing the door hinging

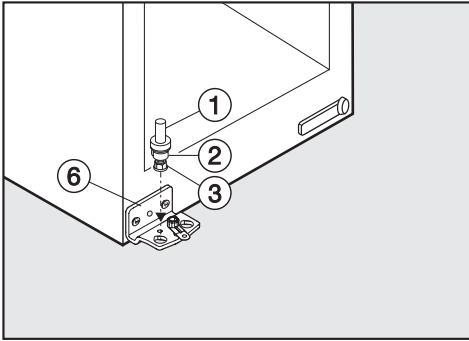

- Screw hinge plate ⑥ into position on the opposite side using the two **outer** long slots only. To make it possible to align the door later, do not replace the **centre** screw at this stage.
- Refit hinge pin ① together with disc ② and adjustable foot ③. Important. The notch at the bottom of the hinge pin should face towards the back.
- Place the door onto hinge pin ①.
- Close the appliance door.

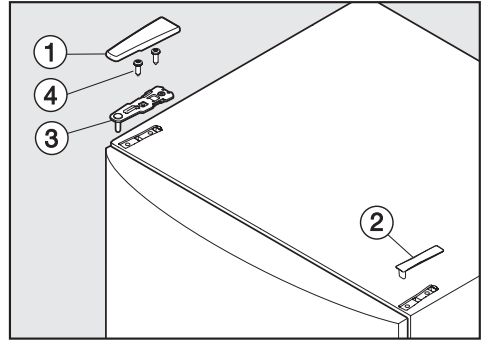

- Fit hinge plate ③ onto the opposite side and secure it with screws ④.
- Fit covers ① and ② to their opposite sides.
- Realign the door with the appliance housing again if necessary using the long slots in the lower hinge plate. Then tighten the screws.

# Changing the door hinging

## Refitting the handle

Please make sure you follow the instructions below carefully when you refit the handle. The door seal will be damaged if the handle is fitted incorrectly.

It is important to check that the side section of the handle ④ does not come into contact with the door seal when opening the door, as this would damage the door seal permanently.

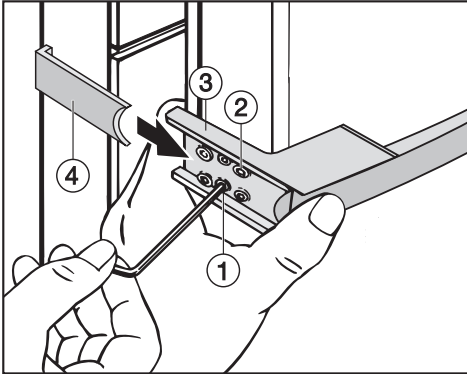

If, after you have refitted the handle, you find that the side section does touch the door seal when the door is opened:

- Realign mounting plate ③ with grub screws ① until the mounting plate and the side section of handle ④ are at the correct angle and the side section does not touch the door seal when the door is opened.

- Loosely attach the handle to the opposite side of the door with the two front screws ②.

Mounting plate ③ must be positioned on the side of the door so that when the door is **closed** it is flush with the side of the appliance.

If this is not the case,

- tighten both grub screws ① with a suitable allen key until mounting plate ③ lines up correctly.
- Then tighten all 4 screws ②.
- Slide the side section of the handle ④ into the guides on the mounting plate until it clicks into place.

## Aligning the appliance door

---

The appliance door can be aligned to the housing using the outer long slots in the lower hinge plate.

In the following illustration the door is not shown in the closed position to make it easier to see what you have to do.

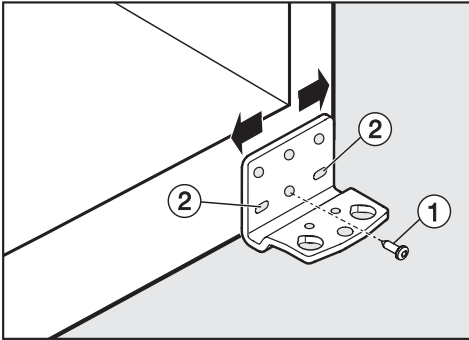

- Remove centre screw ① from the hinge plate.
- Slightly loosen both outer screws ②.
- Align the door by sliding the hinge plate to the left or right.
- Then tighten screws ② again. Screw ① does not need to be used again.

## Building in the appliance

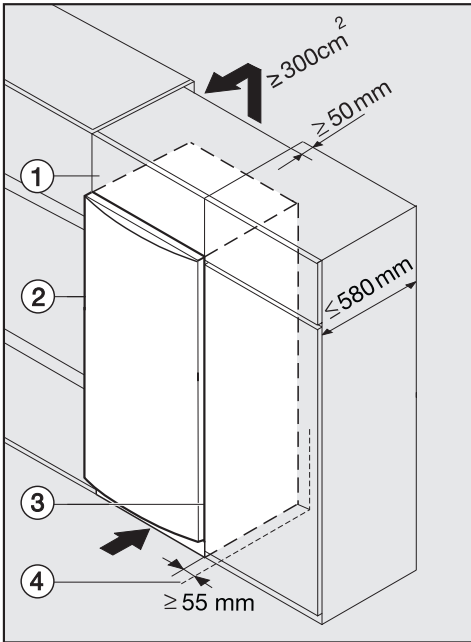

The air inlet and outlet must not be covered or blocked in any way. They should be dusted on a regular basis.

When built into a kitchen run (max. depth 580 mm) the appliance can be installed directly next to a kitchen furniture housing unit. The appliance door will protrude in front of furniture fronts at the sides by 34 mm and by 55 mm in the middle of the door. This enables the doors to be opened and shut without being obstructed.

When installed **next to a wall** ④ a distance of approx. 55 mm must be maintained on the hinge side between the wall ④ and the appliance ②, so that the doors and the handles have sufficient space for opening.

- ① Top box
- ② Appliance
- ③ Housing unit
- ④ Wall

The appliance can be installed in a kitchen run. To match the height of the rest of the kitchen, the appliance can be fitted with a suitable top box ①.

A ventilation gap of at least 50 mm depth must be allowed for behind the appliance across the entire width of the top box for air to circulate.

The cross section of the air outlet under the room ceiling must be at least 300 cm<sup>2</sup> to ensure that air can circulate without hindrance. Otherwise the appliance has to work harder, resulting in an increase in electricity consumption.

## United Kingdom

Miele Co. Ltd.  
Fairacres, Marcham Road  
Abingdon, Oxon, OX14 1TW  
Tel: 0845 365 0555  
Fax: 0845 365 0777  
Customer Contact Centre Tel: 0845 365 6600  
E-mail: [info@miele.co.uk](mailto:info@miele.co.uk)  
Internet: [www.miele.co.uk](http://www.miele.co.uk)

## Australia

Miele Australia Pty. Ltd.  
ABN 96 005 635 398  
1 Gilbert Park Drive, Knoxfield, VIC 3180  
Tel: 1300 464 353, Fax: (03) 9764 7149  
Internet: [www.miele.com.au](http://www.miele.com.au)

## China

Miele (Shanghai) Trading Ltd.  
1-3 Floor, No. 82 Shi Men Yi Road  
Jing' an District  
200040 Shanghai, PRC  
Tel: +86 21 6157 3500  
Fax: +86 21 6157 3511  
E-mail: [miele Shanghai@cn.miele.com](mailto:miele Shanghai@cn.miele.com)  
Internet: [www.miele.cn](http://www.miele.cn)

## Miele (Hong Kong) Limited

41/F - 4101, Manhattan Place  
23 Wang Tai Road  
Kowloon Bay  
Hong Kong  
Tel: (852) 2610 1331  
Fax: (852) 2610 1013  
Email: [mielehk@miele.com.hk](mailto:mielehk@miele.com.hk)

## India

Miele India Pvt. Ltd.  
Ground Floor, Copia Corporate Suites  
Plot No. 9, Jasola  
New Delhi - 110025  
Tel: 011-46 900 000, Fax: 011-46 900 001  
E-mail: [customercare@miele.in](mailto:customercare@miele.in)  
Internet: [www.miele.in](http://www.miele.in)

**Manufacturer:** Germany - Miele & Cie. KG  
Carl-Miele-Straße 29, 33332 Gütersloh

# Miele

## Ireland

Miele Ireland Ltd.  
2024 Bianconi Avenue  
Citywest Business Campus, Dublin 24  
Tel: (01) 461 07 10, Fax: (01) 461 07 97  
E-Mail: [info@miele.ie](mailto:info@miele.ie), Internet: [www.miele.ie](http://www.miele.ie)

## New Zealand

Miele New Zealand Limited  
Unit L, 10-20 Sylvia Park Road  
Mt. Wellington, 1060, Auckland, NZ  
Tel: 0800 264 353, Fax: 0800 463 453  
Internet: [www.miele.co.nz](http://www.miele.co.nz)

## Singapore

Miele Southeast Asia  
Miele Pte. Ltd.  
163 Penang Road  
# 04 - 02/03 Winsland House II  
Singapore 238463  
Tel: +65 6735 1191, Fax: +65 6735 1161  
E-Mail: [infosea@miele.com.sg](mailto:infosea@miele.com.sg)  
Internet: [www.miele.sg](http://www.miele.sg)

## South Africa

Miele (Pty) Ltd  
63 Peter Place, Bryanston 2194  
P.O. Box 69434, Bryanston 2021  
Tel: +27 (0) 11 548-1900  
Fax: +27 (0) 11 548-1935  
E-mail: [info@miele.co.za](mailto:info@miele.co.za)  
Internet: [www.miele.co.za](http://www.miele.co.za)

## United Arab Emirates

Miele Appliances Ltd.  
P.O. Box 11 47 82  
Gold & Diamond Park  
Sheikh Zayed Road  
Building 6 / Offices Nos. 6-214 to 6-220  
Dubai  
Tel: +971-4-341 84 44  
Fax: +971-4-341 88 52  
E-Mail: [info@miele.ae](mailto:info@miele.ae)  
Internet: [www.miele.ae](http://www.miele.ae)